

SYMBOL	DIMENSIONS			NOTES
	MIN.	NOM.	MAX.	
A	4,24	4,44	4,64	
A1	1,15	1,27	1,40	
A2	2,30	2,48	2,70	
b	0,70	0,80	0,90	
b1	1,20	1,55	1,75	
b2	1,20	1,45	1,70	
c	0,40	0,50	0,60	
D	14,70	15,37	16,00	4
D1	8,82	8,92	9,02	
D2	12,63	12,73	12,83	5
E	9,96	10,16	10,36	4,5
E1	6,86	7,77	8,89	5
E2	-	-	0,76	6
E3*	8,70REF.			
e	2,54BSC			
e1	5,08BSC			
H1	6,30	6,45	6,60	5,6
L	13,47	13,72	13,97	
L1	3,60	3,80	4,00	
ØP	3,75	3,84	3,93	
Q	2,60	2,80	3,00	
Q1*	1,73REF.			
R*	1,82REF.			

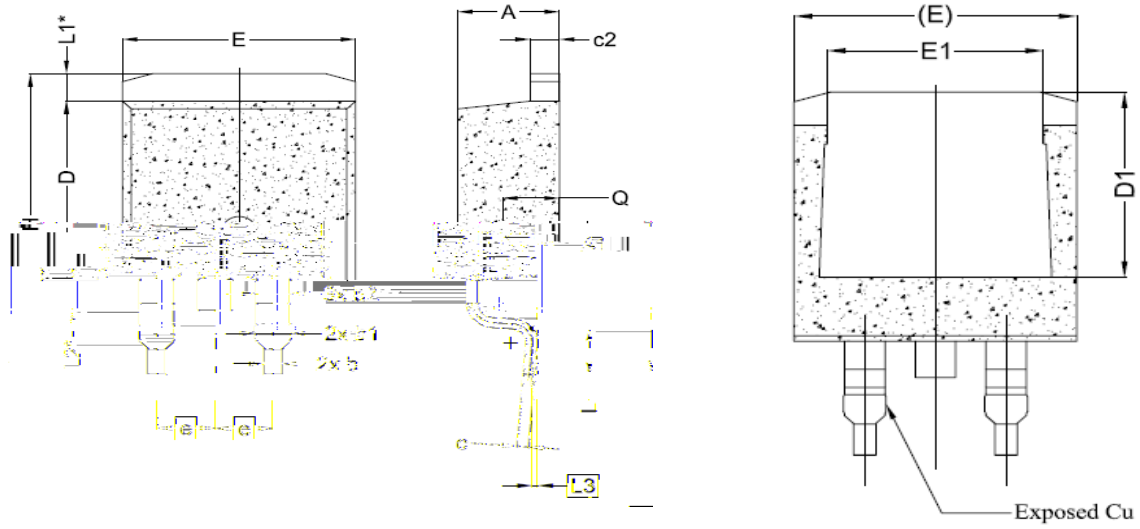

SYMBOL	DIMENSIONS		
	MIN.	NOM.	MAX.
A	4.24	4.44	4.64
A1	0.00	0.10	0.25
b	0.70	0.80	0.90
b1	1.20	1.55	1.75
b2	1.20	1.45	1.70
c	0.40	0.50	0.60
c2	1.15	1.27	1.40
D	8.82	8.92	9.02
D1	6.86	7.65	8.44

19'	2.77	3.29	2.54 BSC	E	9.02
19'	15.30	15.83	1.35 REF.	E1	6.86
18'	3.32	3.79	1.90 REF.	e	
	0.25 BSC			H	14.
				L	1.3
				L1	
				L2	
				L3	
19'	2.48	3.00		Q	2.5

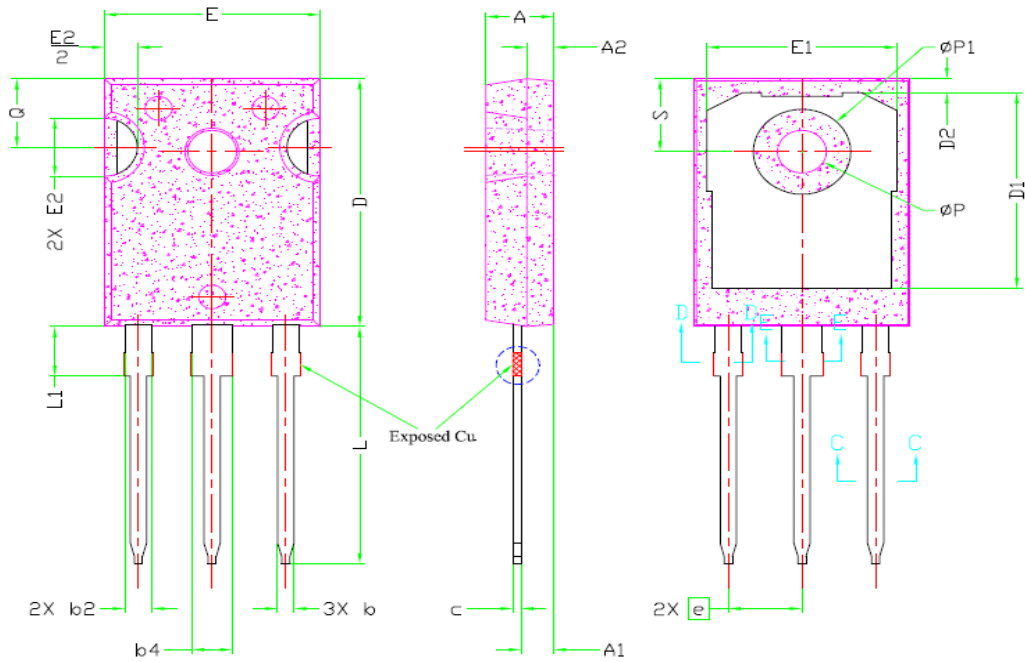

SYMBOL	DIMENSIONS			NOTES
	MIN.	NOM.	MAX.	
A	4.93	5.02	5.21	
A1	4.7	4.81	4.91	0.01
A2	0.4	0.5	0.6	0.01
b	0.1	0.2	0.3	0.01
b1	0.1	0.2	0.3	0.01
b2	0.1	0.2	0.3	0.01
b3	0.1	0.2	0.3	0.01
b4	0.1	0.2	0.3	0.01
b5	0.1	0.2	0.3	0.01
b6	0.1	0.2	0.3	0.01
b7	0.1	0.2	0.3	0.01
b8	0.1	0.2	0.3	0.01
b9	0.1	0.2	0.3	0.01
b10	0.1	0.2	0.3	0.01
b11	0.1	0.2	0.3	0.01
b12	0.1	0.2	0.3	0.01
b13	0.1	0.2	0.3	0.01
b14	0.1	0.2	0.3	0.01
b15	0.1	0.2	0.3	0.01
b16	0.1	0.2	0.3	0.01
b17	0.1	0.2	0.3	0.01
b18	0.1	0.2	0.3	0.01
b19	0.1	0.2	0.3	0.01
b20	0.1	0.2	0.3	0.01
b21	0.1	0.2	0.3	0.01
b22	0.1	0.2	0.3	0.01
b23	0.1	0.2	0.3	0.01
b24	0.1	0.2	0.3	0.01
b25	0.1	0.2	0.3	0.01
b26	0.1	0.2	0.3	0.01
b27	0.1	0.2	0.3	0.01
b28	0.1	0.2	0.3	0.01
b29	0.1	0.2	0.3	0.01
b30	0.1	0.2	0.3	0.01
b31	0.1	0.2	0.3	0.01
b32	0.1	0.2	0.3	0.01
b33	0.1	0.2	0.3	0.01
b34	0.1	0.2	0.3	0.01
b35	0.1	0.2	0.3	0.01
b36	0.1	0.2	0.3	0.01
b37	0.1	0.2	0.3	0.01
b38	0.1	0.2	0.3	0.01
b39	0.1	0.2	0.3	0.01
b40	0.1	0.2	0.3	0.01
b41	0.1	0.2	0.3	0.01
b42	0.1	0.2	0.3	0.01
b43	0.1	0.2	0.3	0.01
b44	0.1	0.2	0.3	0.01
b45	0.1	0.2	0.3	0.01
b46	0.1	0.2	0.3	0.01
b47	0.1	0.2	0.3	0.01
b48	0.1	0.2	0.3	0.01
b49	0.1	0.2	0.3	0.01
b50	0.1	0.2	0.3	0.01
b51	0.1	0.2	0.3	0.01
b52	0.1	0.2	0.3	0.01
b53	0.1	0.2	0.3	0.01
b54	0.1	0.2	0.3	0.01
b55	0.1	0.2	0.3	0.01
b56	0.1	0.2	0.3	0.01
b57	0.1	0.2	0.3	0.01
b58	0.1	0.2	0.3	0.01
b59	0.1	0.2	0.3	0.01
b60	0.1	0.2	0.3	0.01
b61	0.1	0.2	0.3	0.01
b62	0.1	0.2	0.3	0.01
b63	0.1	0.2	0.3	0.01
b64	0.1	0.2	0.3	0.01
b65	0.1	0.2	0.3	0.01
b66	0.1	0.2	0.3	0.01
b67	0.1	0.2	0.3	0.01
b68	0.1	0.2	0.3	0.01
b69	0.1	0.2	0.3	0.01
b70	0.1	0.2	0.3	0.01
b71	0.1	0.2	0.3	0.01
b72	0.1	0.2	0.3	0.01
b73	0.1	0.2	0.3	0.01
b74	0.1	0.2	0.3	0.01
b75	0.1	0.2	0.3	0.01
b76	0.1	0.2	0.3	0.01
b77	0.1	0.2	0.3	0.01
b78	0.1	0.2	0.3	0.01
b79	0.1	0.2	0.3	0.01
b80	0.1	0.2	0.3	0.01
b81	0.1	0.2	0.3	0.01
b82	0.1	0.2	0.3	0.01
b83	0.1	0.2	0.3	0.01
b84	0.1	0.2	0.3	0.01
b85	0.1	0.2	0.3	0.01
b86	0.1	0.2	0.3	0.01
b87	0.1	0.2	0.3	0.01
b88	0.1	0.2	0.3	0.01
b89	0.1	0.2	0.3	0.01
b90	0.1	0.2	0.3	0.01
b91	0.1	0.2	0.3	0.01
b92	0.1	0.2	0.3	0.01
b93	0.1	0.2	0.3	0.01
b94	0.1	0.2	0.3	0.01
b95	0.1	0.2	0.3	0.01
b96	0.1	0.2	0.3	0.01
b97	0.1	0.2	0.3	0.01
b98	0.1	0.2	0.3	0.01
b99	0.1	0.2	0.3	0.01
b100	0.1	0.2	0.3	0.01